



INDUSTRIAL VACUUM SYSTEMS

Product Group  
Mobile Vacuum Units

VacTrailer S-4



The industrial vacuum unit that can do more!

### VacTrailer S-4

Economic series production  
Fills BigBags or open skip containers  
Performance rate up to 12 tons/h  
Pneumatic AirShock® filter cleaning as standard equipment  
The most powerful and economic industrial cleaning and material recovery unit in its class!



Plant cleaning in a coal operated power station



**wieland lufttechnik**  
Wetterkreuz 12  
91058 Erlangen  
Germany  
Phone +49 9131 60 67-0  
Fax +49 9131 60 44 01  
info@wieland-luft.com  
www.wieland-luft.com

## Two different filter separators available!



Filter separator with discharge slide gate DN 300 for dust free discharge into BigBags.



Filter separator with inclined floor and large discharge door for safe discharge of poorly flowing suction material.

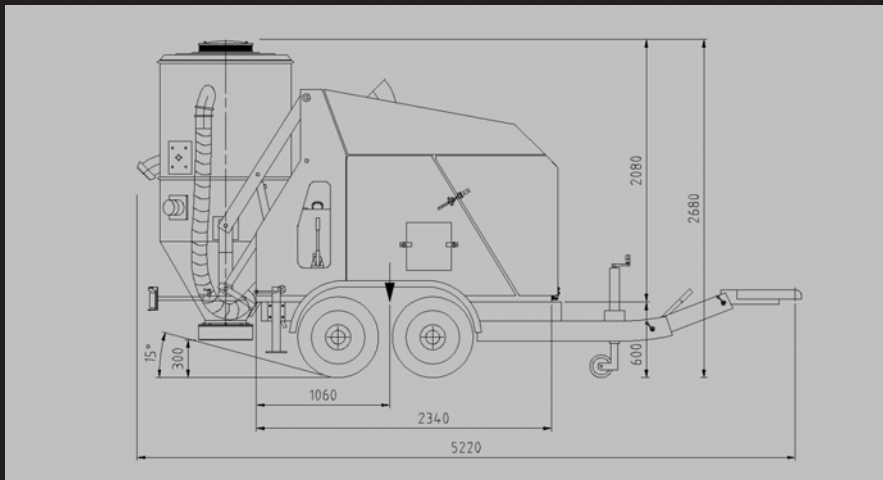

Technical data	Unit	S-4 Diesel / Electric
Max. airflow of vacuum pump	m <sup>3</sup> /h	2100
Suction power, continuously	mbar	500
Diesel engine	kW	48.6
Electric motor	kW	37
Collection container, max. capacity / material weight	Liter / kg	500 / 800
Filter area (Filter for dust dangerous to health, dust class M)	m <sup>2</sup>	12
Safety cartridge filter	m <sup>2</sup>	7.5
Weight without trailer Diesel / Electric approx.	kg	1880 / 1810
Weight of the trailer approx.	kg	420
Noise level, 7 m distance, reflexion-free, average value Diesel / Electric	dB(A)	77 / 75

## Easy transport

A van, see left picture, is the most economical means of transport for the S-4 unit. Sufficient space is available for accessories. The empty weight of the S-4 unit including a tandem trailer is 2300 kg

## Designed for the versatile requirements of professional industrial cleaning contractors

- discharges into BigBags or into open skip containers
- conveys suitable suction material over more than 100 m, suction hoses DN 80 / DN 100
- suction rate up to 12 tons/h
- suitable for suction of dry, wet and hazardous material (dust class M / H)
- Diesel or electric drive
- Two filter stages
- Rotary piston vacuum pump
- Filling level probe

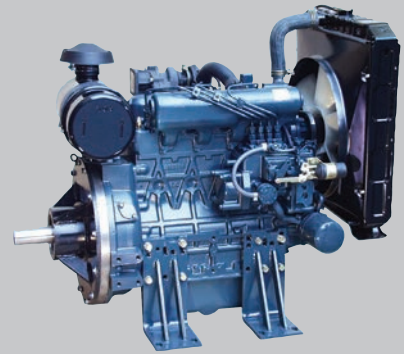

Kubota industrial Diesel engine, water cooled, turbocharged, for continuous operation, 48.6 kW

Easy maintenance of the high tech filter unit. The filter packages can be taken out of the filter housing for inspection. Pneumatic AirShock® filter cleaning device as standard equipment.

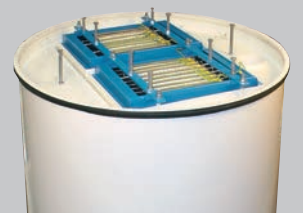

0517-430/1